

Oslo

Mesh back operator chair

CHO201



UNPACKING INSTRUCTIONS

- Do not use a knife or sharp object to open the carton.
- Carefully open the carton, remove the contents and lay them out on cardboard or other protective surface to avoid damage.
- Check package contents against the Parts List on the next page to ensure that all components have been received.
- Do not use damaged or defective parts, report any discrepancies within 48 hours of receipt of goods.
- Carefully read and understand all instructions before attempting assembly, see notes on back page.

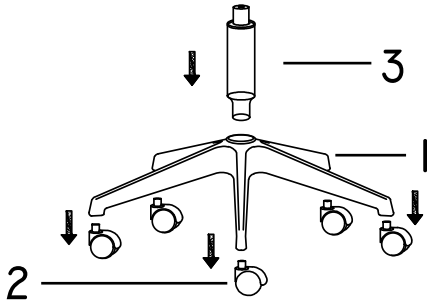

A. Install castors (2) to Base (1)

NOTE: Ensure the castors are fully pushed into the base before use.

B. Put the gas lift (3) into Base (1)

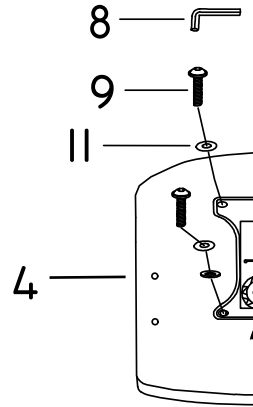

C. Fit the Mechanism (5) to the seat (4) - (knob towards the front)

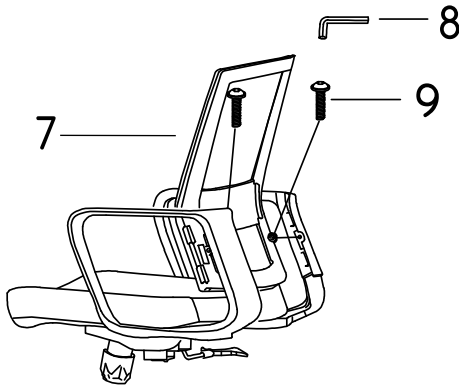





E. Fit the Back (7) to the arms and start the screws.

Note: Now tighten all screws evenly (Fig: D and E.)



F. Carefully lower the Mechanism (5) with the assembled seat onto the base (1)

ITEM No:	1	2	3	4	5
ITEM:					
DESCRIPTION:	BASE	CASTOR	GAS LIFT	SEAT	MECHANISM
QUANTITY:	1	5	1	1	1

Tighten the screws evenly a little at a time following a diagonal pattern

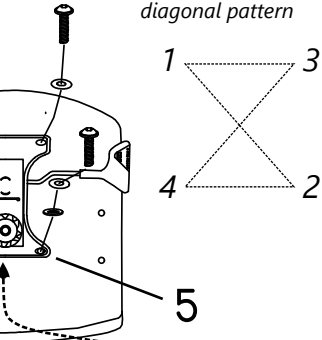

to the seat.
(of the seat)

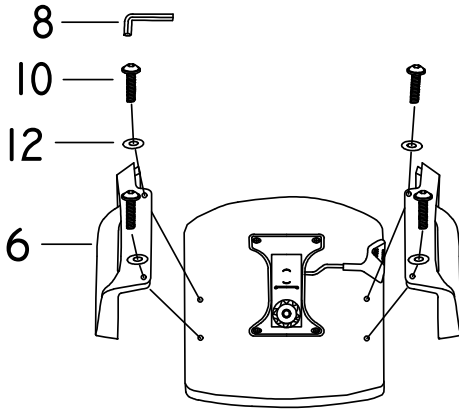

D. Fit the Arms (6) to the Seat. *Note: Do not fully tighten until the Back is located and all screws started*



align the socket
in the Gas lift (3) and lower
the gas lift.



6	7	8	9	10	11	12
ARMS LEFT & RIGHT	BACK	HEX KEY	M6x20	M6x30	6MM WASHER	8MM WASHER
2	1	1	6	4	4	4

Assembly Hints & Tips

1. Unpack on a soft surface (carpet or cardboard) and identify all parts and fixings.
2. Read and understand the instructions.
3. Have tools ready for the job, Hexagon key, (supplied)
4. To avoid cross threading screws, start all threads by hand, not with power drill.
5. Always start all the screws in a component loosely first before tightening. E.g. when fitting the arm start all screws before tightening any.
6. Always tighten screws equally to prevent uneven stress and misalignment of components.
7. Double check final tightness of all fixings before use.

Adjustment and use

1. Right lever - height adjustment;

- 1.1 Twist the paddle lever and gently stand to raise seat, release lever to lock height.
- 1.2 Twist the paddle lever and sit to lower the seat.

2. Right lever - tilt adjustment;

- 2.1 Pull out horizontally to release free floating tilt action.
- 2.2 Sit upright and push the lever in (towards the gas lift) to lock the backrest in the upright position.

3. Seat tilt spring tension;

- 3.1 Adjust the knob under the seat to match the spring tension to the operators body weight (to provide comfortable support when leaning against the backrest)

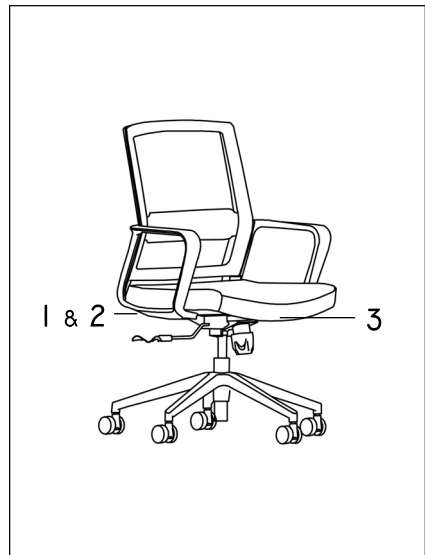

Maintenance & Care

1. Hard surfaces should be regularly wiped with a micro fibre cloth or similar.
2. Soft furnishing should be regularly vacuumed using a brush type upholstery attachment.
3. Wet spills should be immediately blotted dry and treated with a proprietary upholstery cleaner as directed.
4. A check of all screws and fasteners during the first month of use and periodically thereafter is advisable.