

Alto 1

Electric height adjustable desk frame
HAFS121

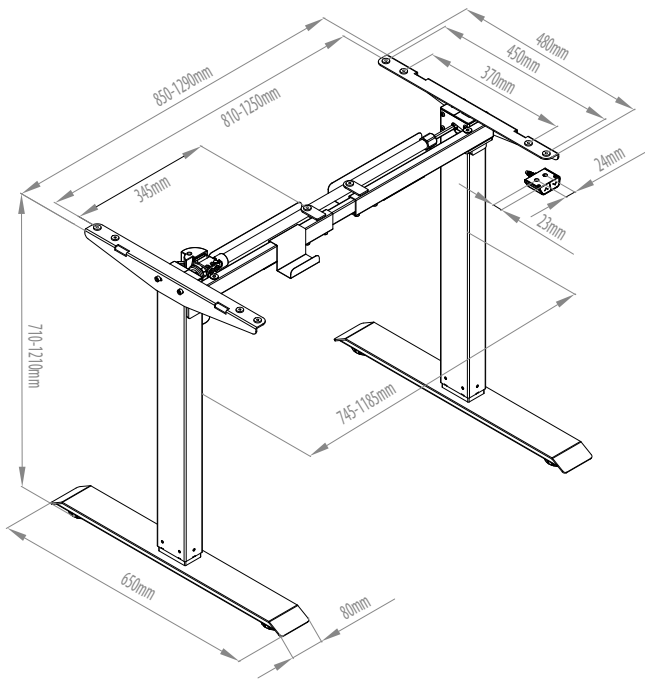

Technical specifications

Frame	2 stage reversed rectangular columns
Finishes	Black / White / Silver
Height range	710-1210 mm
Stroke length	500mm
Load capacity	154lbs / 70kg
Motor	Single
Motor speed	25mm/s
Power	100-240 v
Sound level	<50dB
Desktop width	1000-1600 mm
Desktop depth	500-800 mm
Control panel	Height adjustment (up/down)
Warranty	5 years

Features

- Smooth height adjustment - no juddering
- Simple, easy-to-use control panel
- Anti-collision system
- Ultra quiet motor, lower than 50dB
- Easy to assemble

Boxed specifications

Dimensions	W830 x D280 x H160 mm
Weight	23kg <i>*Caution: Heavy*</i>