

Alto 2

Electric height adjustable desk frame
HAFS233

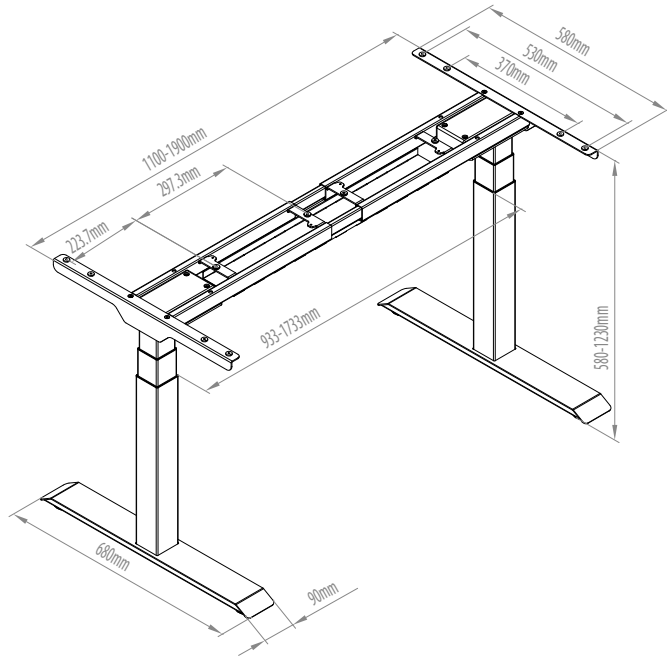

Technical specifications

Frame	3 stage holeless square columns Integrated cable tray
Finishes	Black / White / Silver
Height range	580-1230 mm
Stroke length	650mm
Load capacity	275lbs / 125kg
Motor	Twin/Dual Anti-collision system
Motor speed	38mm/s
Power	100v-240v
Sound level	<50dB
Desktop width	1100-1900 mm
Desktop depth	700 or 800 mm
Control panel	Height adjustment 3 height memory presets Height display Reminder timer function
Warranty	5 years

Features

- Fast and smooth height adjustment - no juddering
- Programmable control panel with 3 height memory presets, digital height display and reminder timer
- **Anti-collision safety system with adjustable sensitivity**
The anti-collision works by sensing change in the electrical current to the motor in the event of a collision. An additional sensor in the control box detects when the desk is not level. Either condition will cause the motor to stop and return 50mm in the opposite direction. The sensitivity is adjusted through the control switch on the desk edge, instructions are in the handbook.
- Holeless column legs
- Integrated cable tidy
- Ultra quiet motor, lower than 50dB
- Easy to assemble

Boxed specifications, 3 boxes

Dimensions	W1150 x D250 x H205 mm
Weight	33kg <i>*Caution: Heavy*</i>