

# Duro

Heavy duty monitor arm, for 3 screens  
PMA323

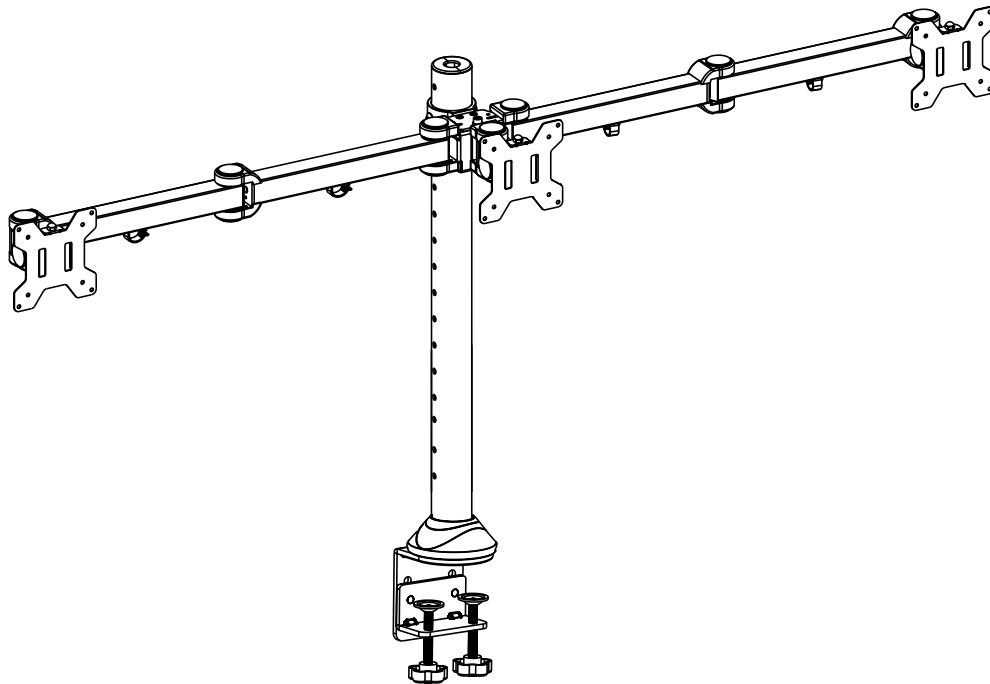

## Technical specifications

<b>Capacities</b>	3 x 10kg Up to 24" (maximum screen width 600mm)
<b>Clamp</b>	Depth: 0 - 100mm
<b>Materials</b>	Steel
<b>Warranty</b>	5 years
<b>Certification</b>	BS EN ISO 9241 Workplace Ergonomics
	PP 045 Safety & Durability

## Features

- Removeable 75mm/100mm VESA mounting plates with hand-turn fixing screws
- Includes desk edge clamp and through-desk clamp
- Complete cable management
- Available in black

## Boxed specifications

<b>Dimensions</b>	W755 x D290 x H130 mm
<b>Weight</b>	8.3kg